

Z230 oxygen analysers

Zirconia sensor analysers for oxygen

- Proven technology from gas analyser experts
- Fast response, integral sensor
- ppm to % O₂ levels
- Non-depleting, long life sensor
- Choice of sample systems



Applications

- Nitrogen generators
- Inert gas systems
- Air separation
- Soldering systems
- Reflow ovens
- Packaging
- Gloveboxes

The Z series of oxygen analysers feature sensors based on zirconium oxide technology. They have the advantages of fast response times, excellent accuracy at ppm levels and a non-depleting sensor for long life. A range of different configurations and internal sample systems are available – so we can find the product that is right for you.

Choose the Z230 for versatility and portability. This benchtop analyser is a fully self contained, complete unit with integral sensor and pump (optional). The carrying handle makes it easily transportable and the integral flowmeter and valve mean there are no further accessories or consumables to carry around. The analyser features bi-directional RS232 allowing remote calibration and datalogging. There is a choice of outputs and both outputs and alarms are user programmable. The internal pump option is chosen if there is insufficient flow in the sample stream and, for applications where a long sample path is involved, a bypass flow sample system enables faster results.

Not all zirconia sensors are the same. Hitech Instruments manufacture zirconia sensors in-house. Careful choice of raw materials and Hitech's manufacturing 'know

how' result in a fast responding, robust sensor with excellent specification and a very fast warm-up time. Different sample systems are available for applications involving long sample paths and high pressure. Bespoke designs are also available according to the application.

Oxygen is measured in a wide variety of processes to confirm the presence or the absence of it. The most common application is to measure oxygen as the impurity in other gases, e.g. nitrogen generators. Oxygen is required in aerobic processes and situations that require user intervention, e.g. to ensure that it is safe to enter a chamber for maintenance work. Some processes require the absence of oxygen to be efficient, e.g. furnace atmospheres, others just require a low level of oxygen for safety reasons, e.g. inert gas blanketing.

Hitech offer a number of different solutions for oxygen measurement dependent on the application. Our technical sales engineers will be pleased to advise the system that is right for you.

The Z series from Hitech Instruments – the last word in fast, ppm oxygen measurement.

SPECIFICATION

Display

Multi-digit LCD

Display range

0.01ppm to 100%, auto ranging

Display Resolution

From 10.0% to 99.9% 0.1%
 From 1.00% to 9.99% 0.01%
 From 0.100 to 0.999% 0.001%
 From 100ppm to 999ppm 1ppm
 From 10.0ppm to 99.9ppm 0.1ppm
 From 0.00ppm to 9.99ppm 0.01ppm

Accuracy

25% to 100ppm: $\pm 2\%$ of reading or better
 99ppm to 10ppm: $\pm 1\text{ppm}$
 0ppm to 9.9ppm: $\pm 0.1\text{ppm}$

Stability

Better than 2% of reading or 0.5ppm/month, whichever is greater

Sample flow

Between 100 and 300ml/min for optimum operation

Speed of response

T90 less than 4 seconds at 300ml/min sample flow

Sample inlet pressure (no pump fitted)

10mbar to 8bar

Sample temperature

100°C maximum at the analyser

Sampling system material

Dependent upon sampling system:
 Stainless steel, platinum, zirconia, nickel, brass aluminium alumina, PTFE, nitrile-rubber and nylon

Sample connections

Dependent upon sampling system:
 Nickel plated brass (captive seal suitable for 6mm/0.25" O.D. pipe)

Analogue output - isolated

0 to 5 volts – minimum load 10k ohms or
 4 to 20mA – maximum load 500 ohms
 Programmable for full scale values of between 1ppm and 100% oxygen and zero scale values of between 0ppm and 90%

Alarm outputs

2 alarms each user programmable for:
 Mode - HIGH, LOW or OFF.
 Level - full range of instrument.
 Hysteresis - 0% to 10% of set point.
 Volt free C/O contacts rated at 48V 0.5A
 AC or DC, normally energised

Serial Communication Port

RS232 DCE (9-pin female D connector)

Environment

Operating: 0°C to +45°C,
 RH <90% (non-condensing)

Power supply

90-260V AC 50/60 Hz unit,
 Maximum power consumption 30VA.

Dimensions

255mm (w) x 170mm (h) x 260mm (d)

Enclosure details

Material: Mild steel

Weight: 6kg

ORDERING INFORMATION

Part no.	Model no.	Description
828-9001	Z230	Bench top oxygen oxygen analyser, 4-20mA output
828-9002	Z230	Bench top oxygen oxygen analyser, 4-20mA output, with bypass flow system
828-9003	Z230	Bench top oxygen oxygen analyser, 4-20mA output with internal pump
Options		Double ferrule sample connectors in brass or stainless steel
		Internal pump and bypass flow system
		Terminal interface software to provide datalogging

Rear view of analyser

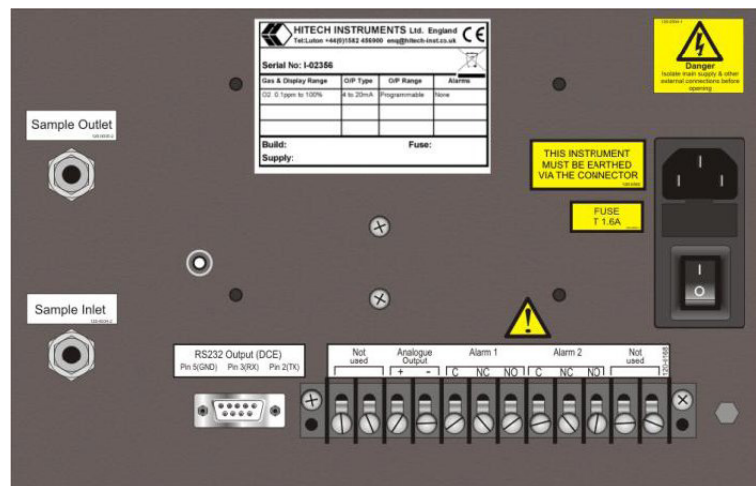

Pump & bypass sample flow system option

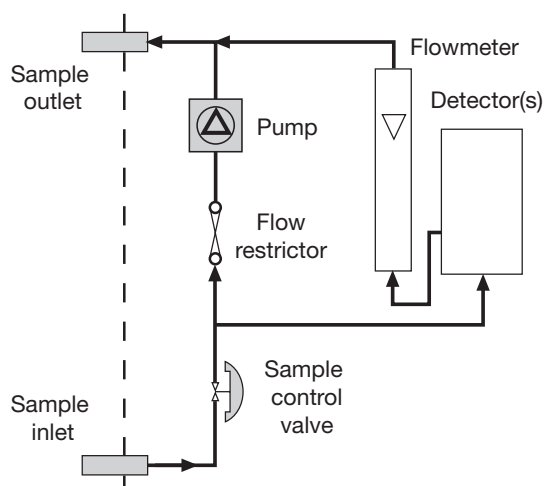

Example of sample system for ppm levels with both pump and bypass flow. A pump is included when the sample pressure is insufficient to allow an adequate flow through the system. The bypass flow enables a fast response over long sample paths. The pressure drop across the flow restrictor is arranged to produce a total flow approximately ten times that of the sample going through the detector.